

G25 Series

Maximum Flow Rate: 76 l/min (20.0 gpm)
Maximum Pressure: 69 bar (1000 psi) for Metallic Pump Heads
24 bar (350 psi) for Non-metallic Pump Heads

API 674



WANNER
Hydra-Cell[®]
Seal-less Pump Technology



G25 with Cast Iron pump head.

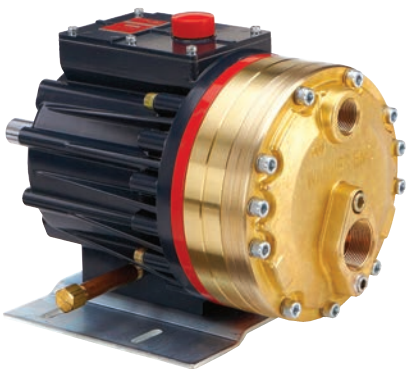

G25 with Brass pump head.

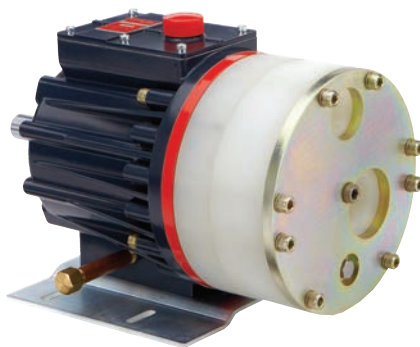

G25 with Polypropylene pump head.

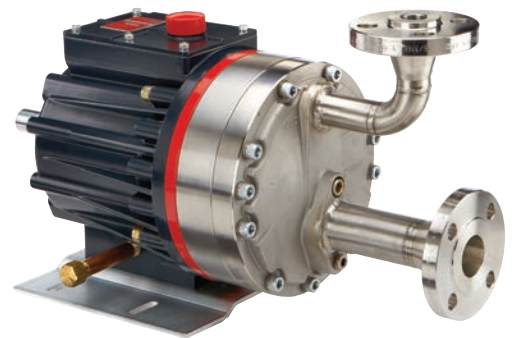

G25 with Stainless Steel pump head and ANSI RF flanges.

G25 Series Performance

Capacities

Flow

Model	Max. Input rpm	Max. Flow @ 69 bar (1000 psi)	
		gpm	l/min
G25-X	1050	20.0	75.7
G25-E	1150	20.0	75.9
G25-S	1150	16.2	61.5
G25-I	1150	11.8	44.7

Pressure

Maximum Inlet Pressure
17 bar (250 psi)

Maximum Discharge Pressure
Metallic Pump Heads:
69 bar (1000 psi)
Non-metallic Pump Heads:
17 bar (250 psi) Polypropylene
24 bar (350 psi) PVDF

Performance and specification ratings apply to G25 configurations unless specifically noted otherwise.

Metering & Dosing

API 675 Performance Characteristics of Steady State Accuracy $\pm 1\%$, Linearity $\pm 3\%$ and Repeatability $\pm 3\%$ can be achieved at speeds up to 1050 rpm and pressures up to 24 bar (non-metallic pump heads) or up to 69 bar (metallic pump heads) for X-cam pumps only.

Maximum Flow at Designated Pressure

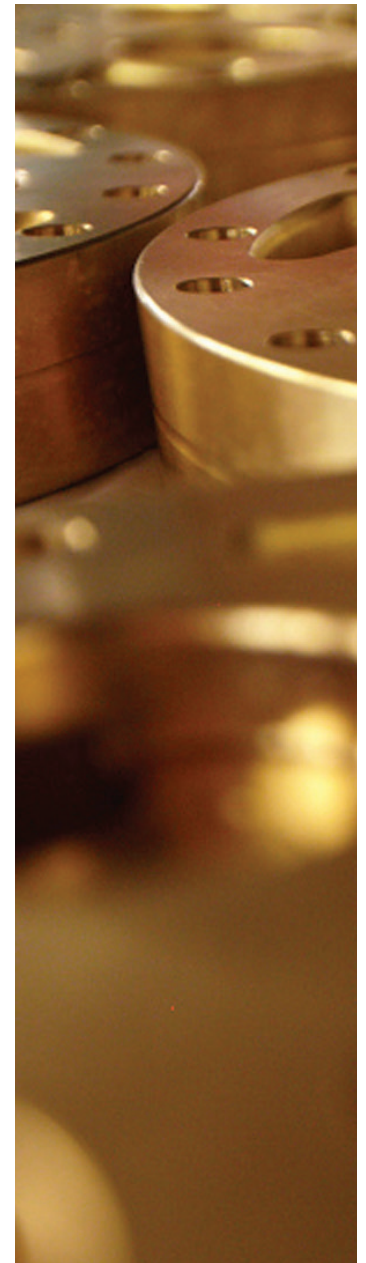
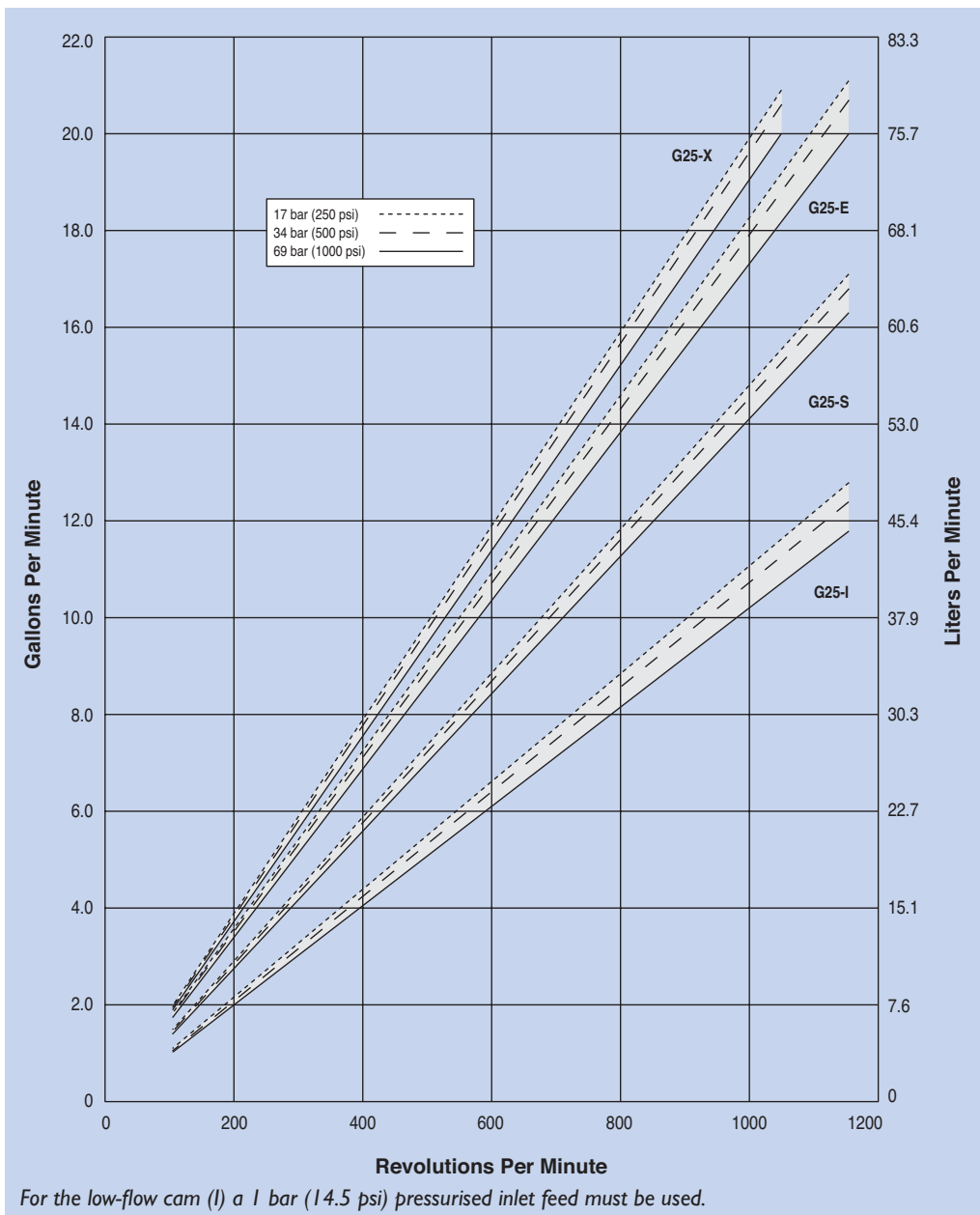

G25 Series Specifications

Flow Capacities @ 69 bar (1000 psi) 6-pole Motor @ 50 Hz

Model	rpm	gpm	l/min
G25-X	960	18.2	69.0
G25-E	960	16.6	63.0
G25-S	960	13.2	50.0
G25-I	960	9.5	36.0

Flow Capacities @ 69 bar (1000 psi) 8-pole Motor @ 50 Hz

Model	rpm	gpm	l/min
G25-X	730	13.9	52.8
G25-E	730	12.9	48.8
G25-S	730	10.3	39.1
G25-I	730	7.9	29.9

Delivery @ 69 bar (1000 psi)

Model	gal/rev	liters/rev
G25-X	0.0190	0.0721
G25-E	0.0174	0.0660
G25-S	0.0141	0.0535
G25-I	0.0103	0.0389

Maximum Discharge Pressure

Metallic Heads:	69 bar (1000 psi)
Non-metallic Heads:	17 bar (250 psi) Polypropylene 24 bar (350 psi) PVDF

Maximum Inlet Pressure 17 bar (250 psi)

Maximum Operating Temperature

Metallic Heads:	121 °C (250 °F) - Consult factory for correct component selection for temperatures from 71 °C (160 °F) to 121 °C (250 °F).
Non-metallic Heads:	60 °C (140 °F)

Maximum Solids Size 800 microns

Inlet Port	1-1/2 inch BSPT
	1-1/2 inch NPT
	150lb ANSI RF Flange
	2 inch Tri-clamp

Discharge Port	1 inch BSPT
	1 inch NPT
	600lb ANSI RF Flange
	1 inch Tri-clamp

Shaft Diameter 28.6 mm (1-1/8 inch)

Shaft Rotation Reverse (bi-directional)

Bearings Tapered roller bearings

Oil Capacity 3.1 litres (3.3 US quarts)

Weight

Metallic Heads:	56.8 kg (125 lbs.)
Non-metallic Heads:	40.9 kg (90 lbs.)

Calculating Required Power

$$\frac{50 \times \text{rpm}}{63,000} + \frac{\text{gpm} \times \text{psi}}{1,460} = \text{electric motor hp}$$

$$\frac{50 \times \text{rpm}}{84,428} + \frac{\text{l/min} \times \text{bar}}{511} = \text{electric motor kW}$$

Calculating Pulley Size

$$\frac{\text{motor pulley OD}}{\text{pump rpm}} = \frac{\text{pump pulley OD}}{\text{motor rpm}}$$

When using a variable frequency controller (VFD) calculate the hp or kW at minimum and maximum pump speed to ensure the correct hp or kW motor is selected. Note that motor manufacturers typically de-rate the service factor to 1.0 when operating with a VFD.

Net Positive Suction Head (NPSHr)

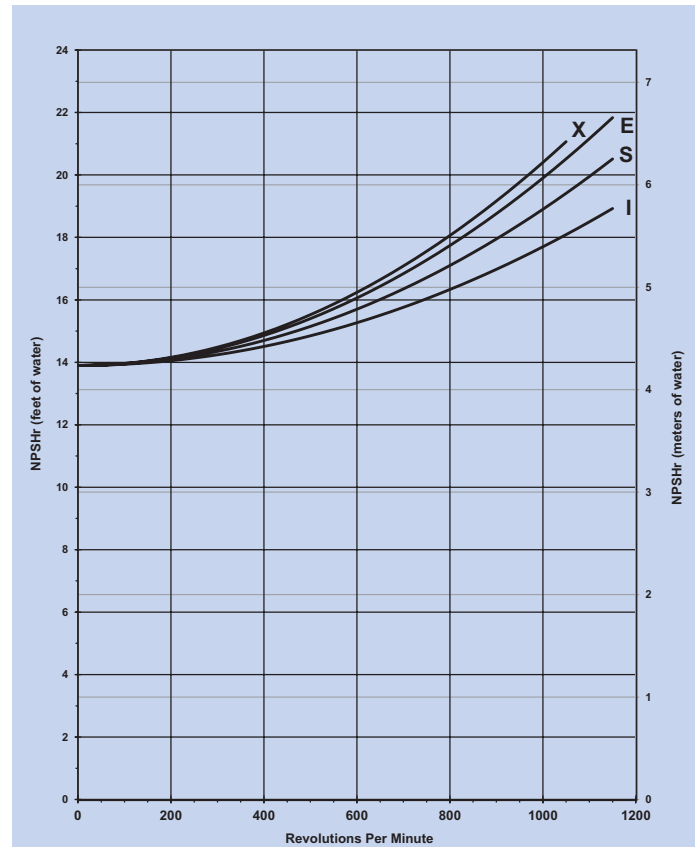

Note: Positive inlet pressure required with PTFE diaphragms.

Self-priming:

Each Hydra-Cell pump has different lift capability depending on model size, cam angle, speed, and fluid characteristics. To ensure that your specific lift characteristics are met, refer to the inlet calculations regarding friction, and acceleration head losses in your Hydra-Cell Installation & Service Manual. Compare those calculations to the NPSHr curves above.

G25 Series General Assemblies

Baseplate Assembly with Motor Adaptor for IEC 132 Motor Frame

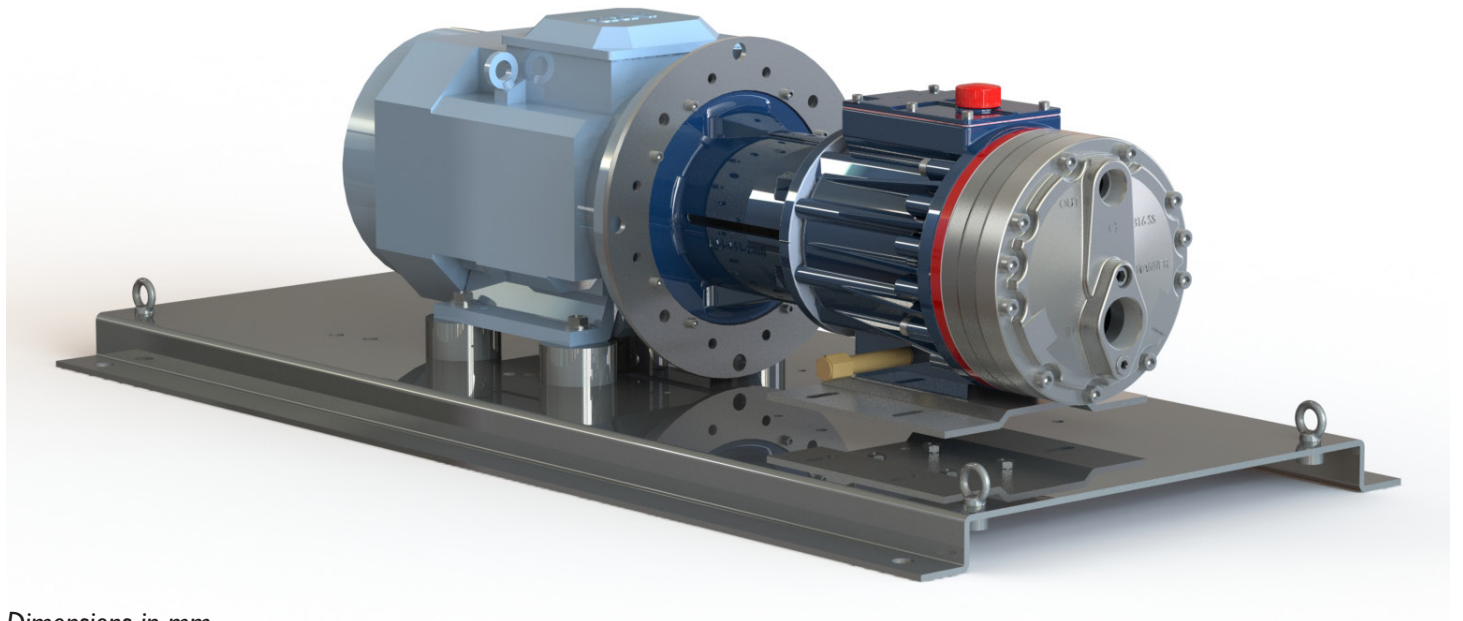

Dimensions in mm

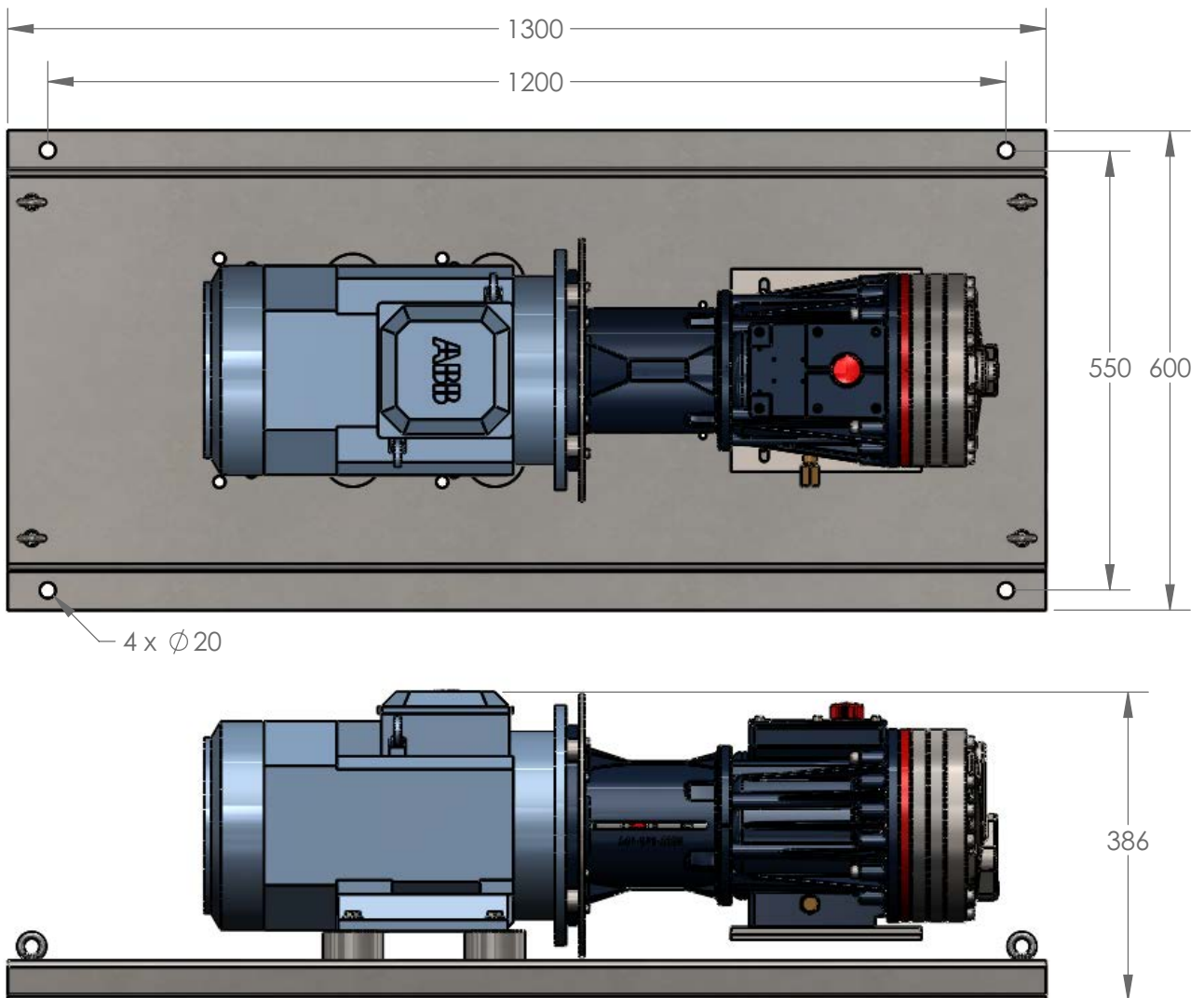

G25 Series General Assemblies

Baseplate Assembly Long-coupled for IEC 132 Motor Frame

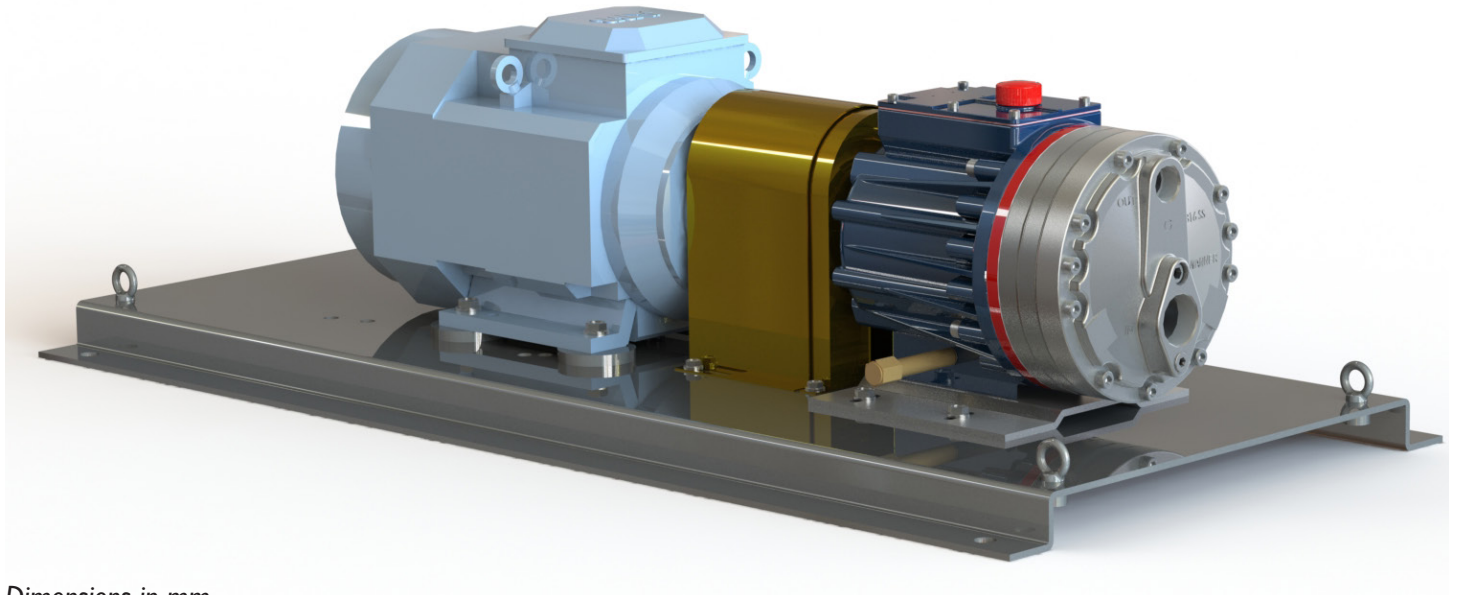

Dimensions in mm

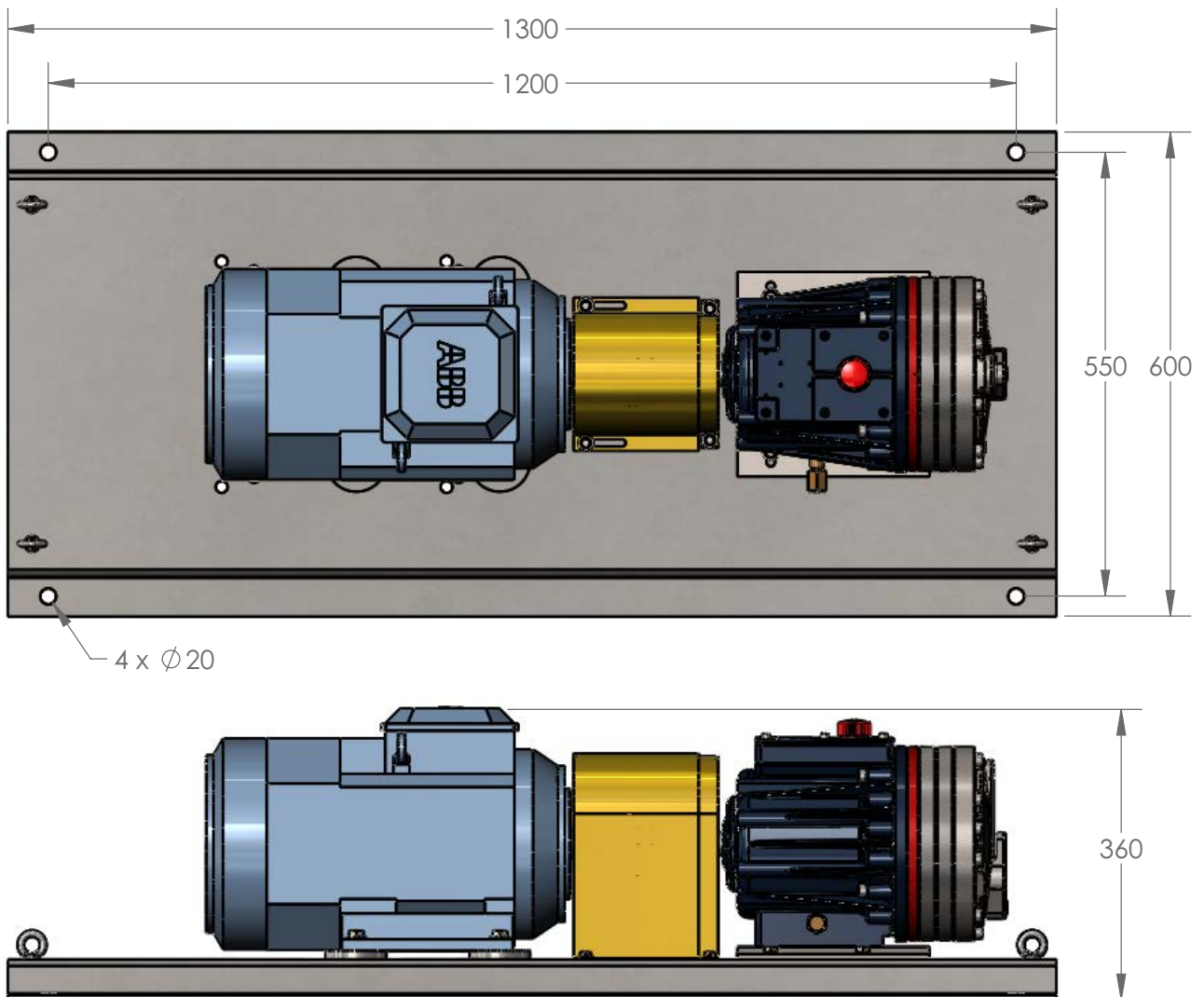

G25 Series General Assemblies

Baseplate Assembly with Motor Adaptor for IEC 160 Motor Frame

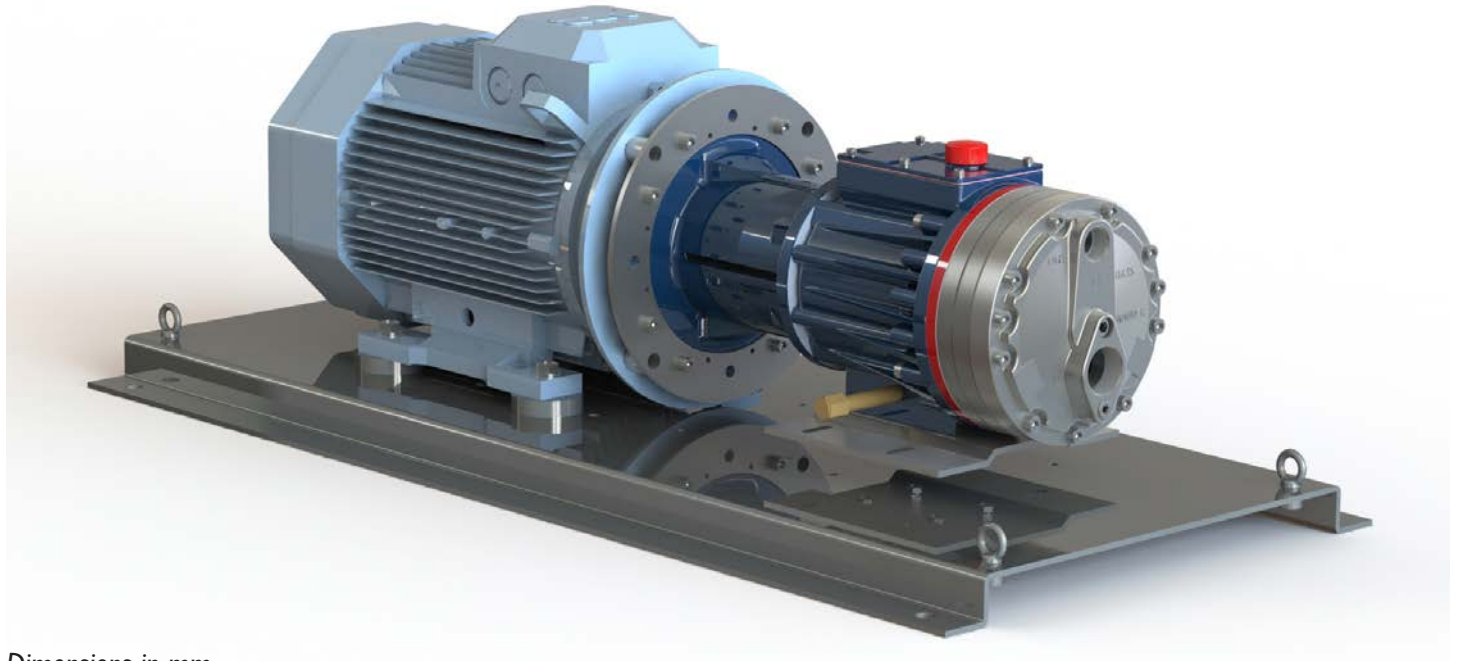

Dimensions in mm

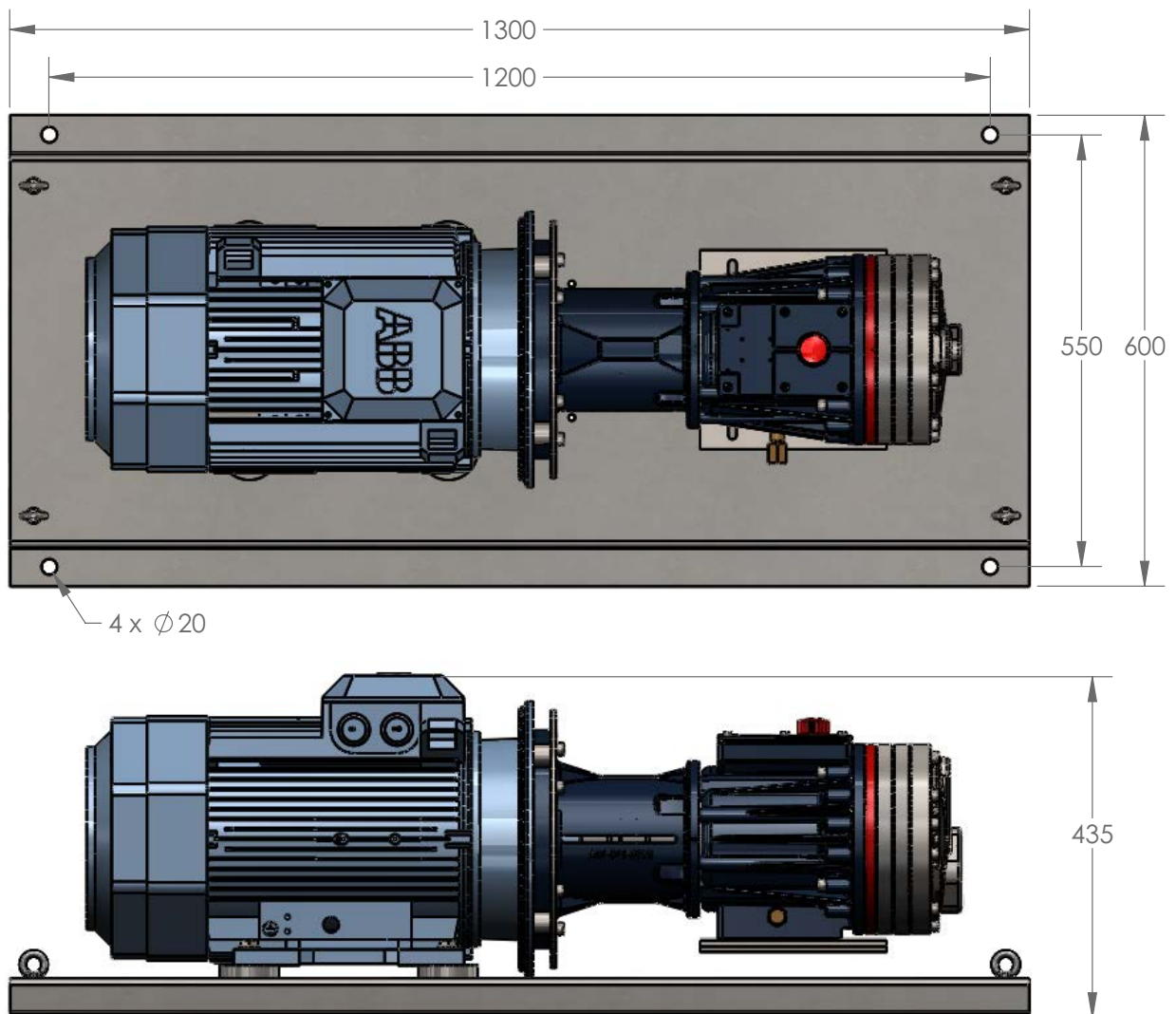

G25 Series General Assemblies

Baseplate Assembly Long-coupled for IEC 160 Motor Frame

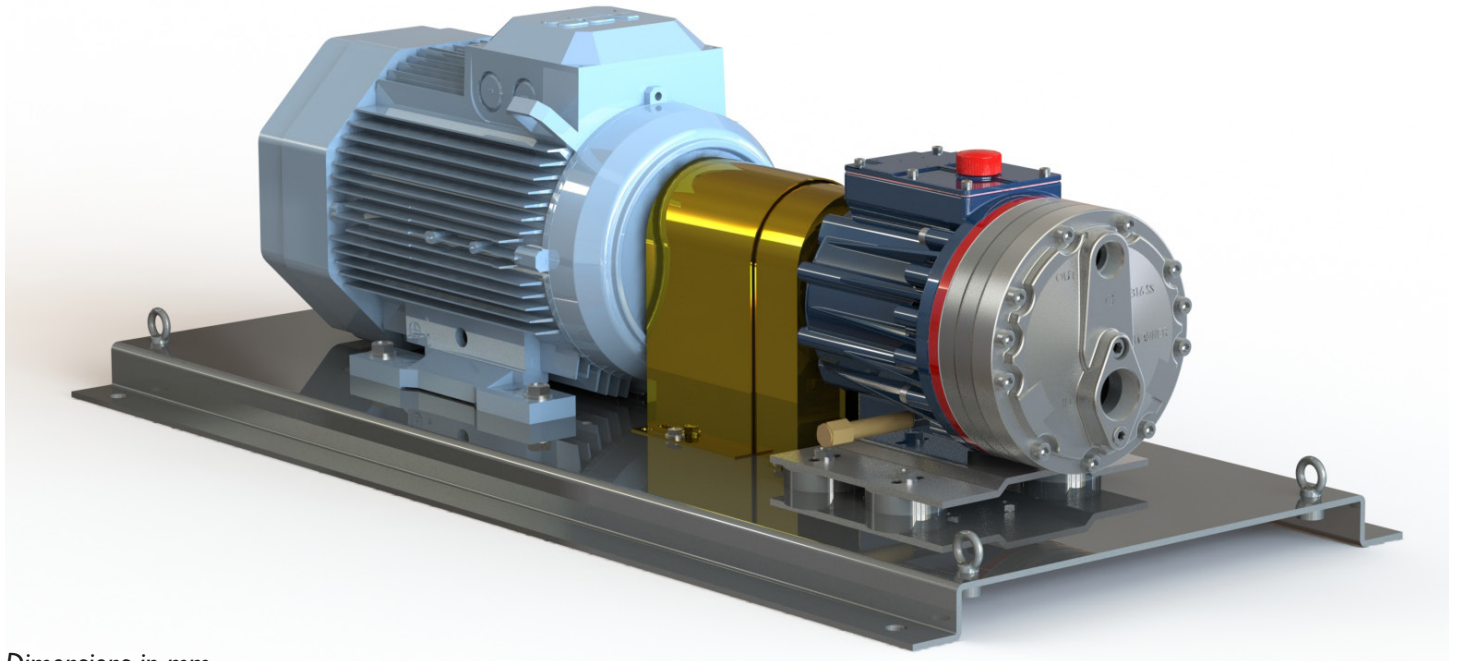

Dimensions in mm

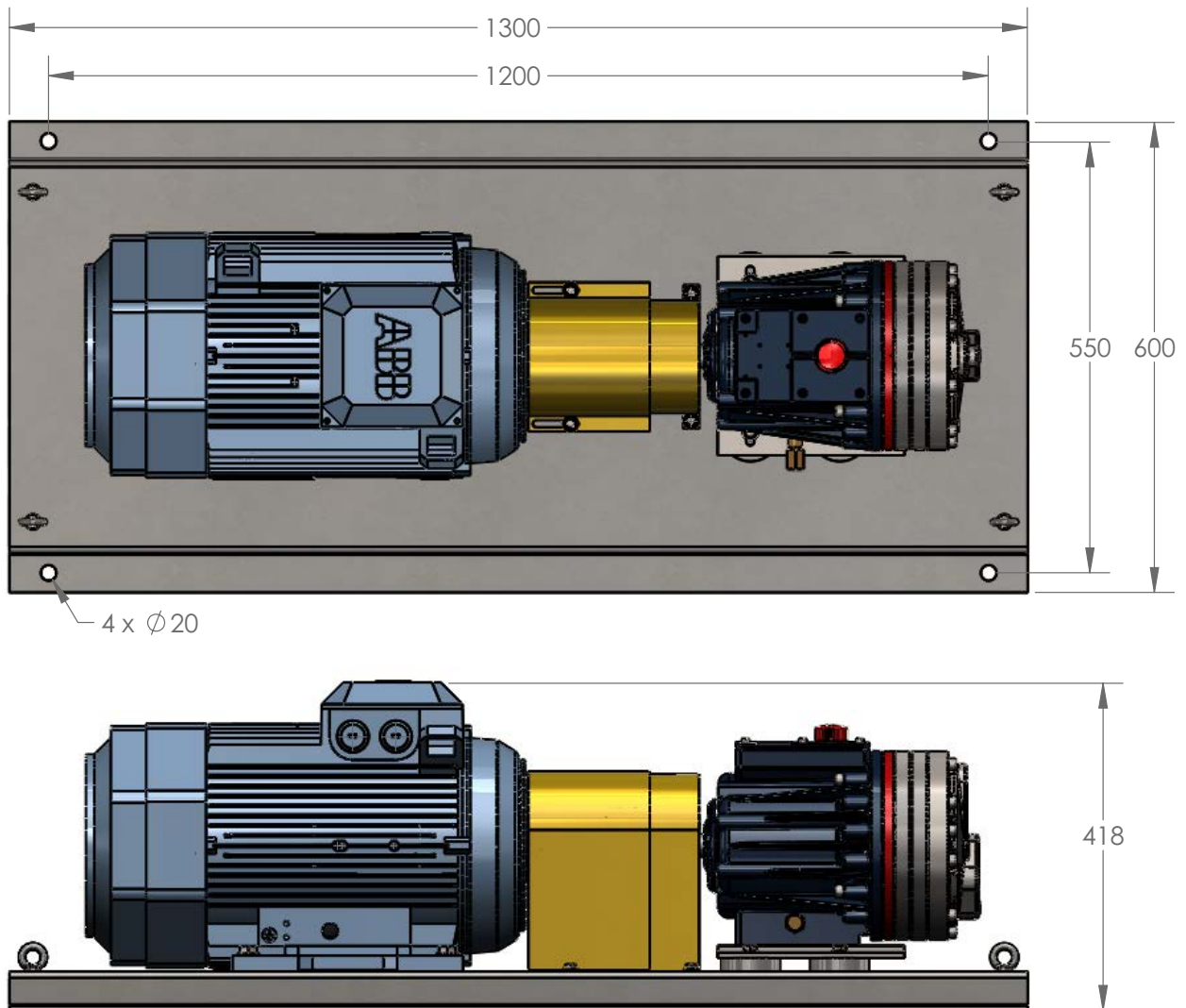

G25 Series General Assemblies

Baseplate Assembly with Motor Adaptor for IEC 180 Motor Frame



Dimensions in mm

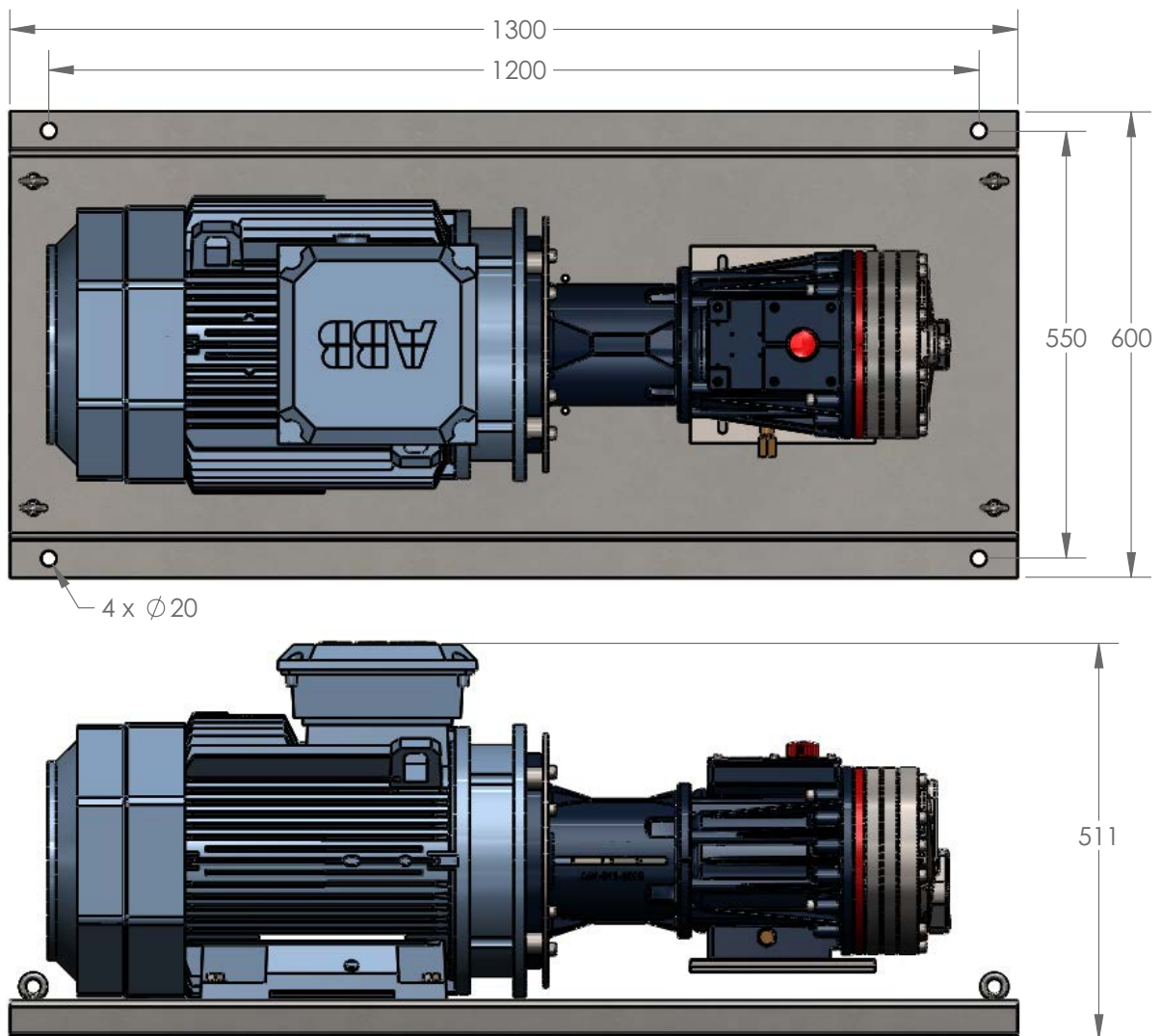

G25 Series General Assemblies

Baseplate Assembly Long-coupled for IEC 180 Motor Frame

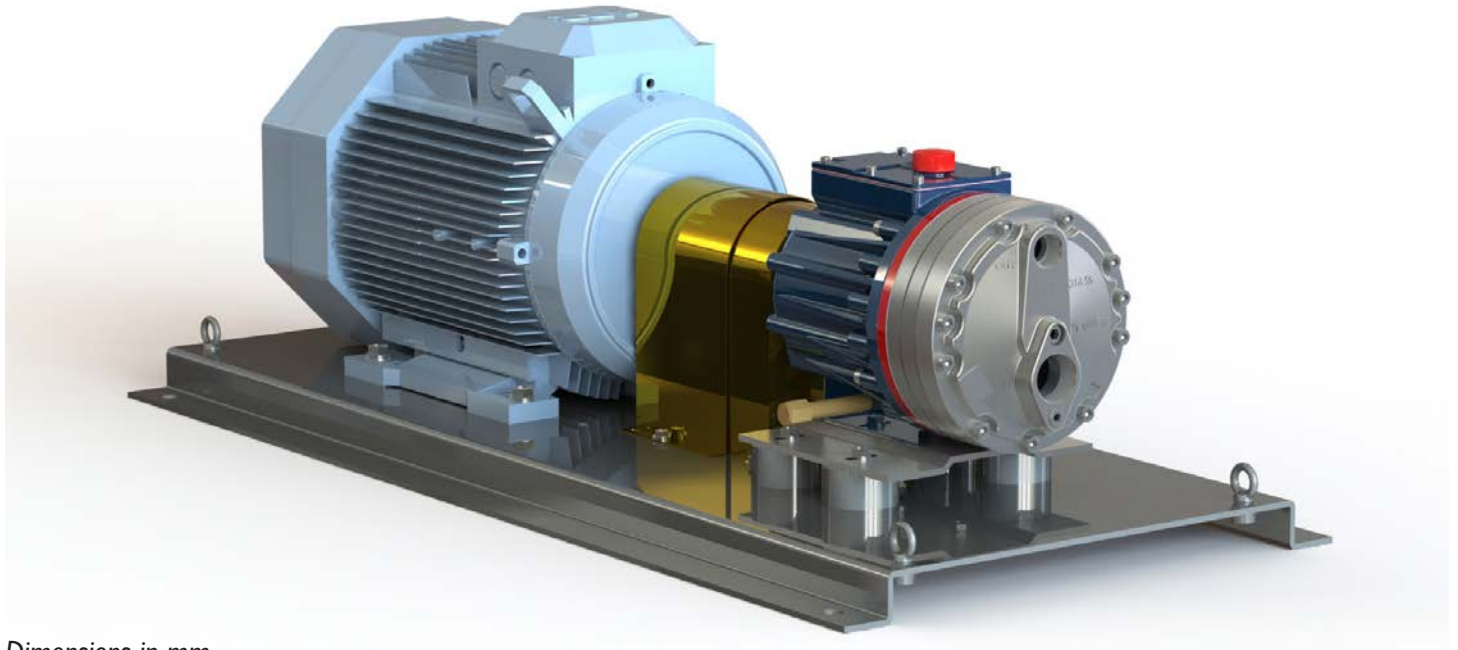

Dimensions in mm

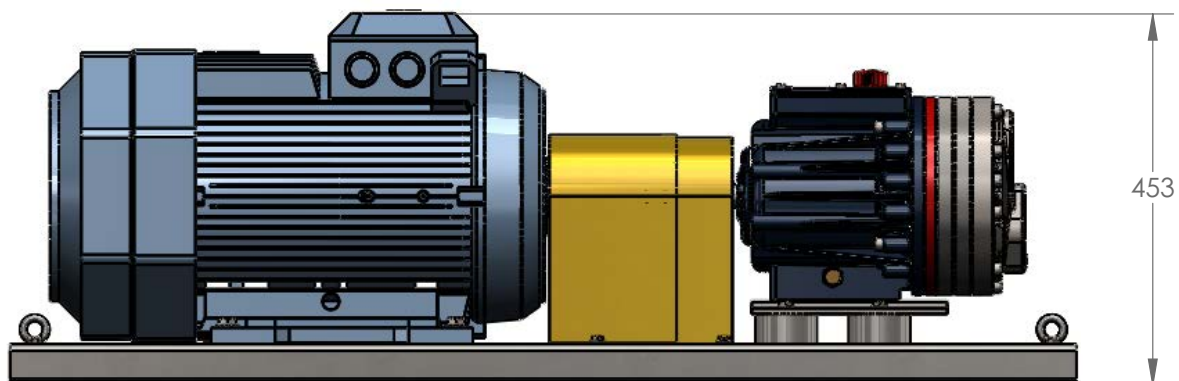
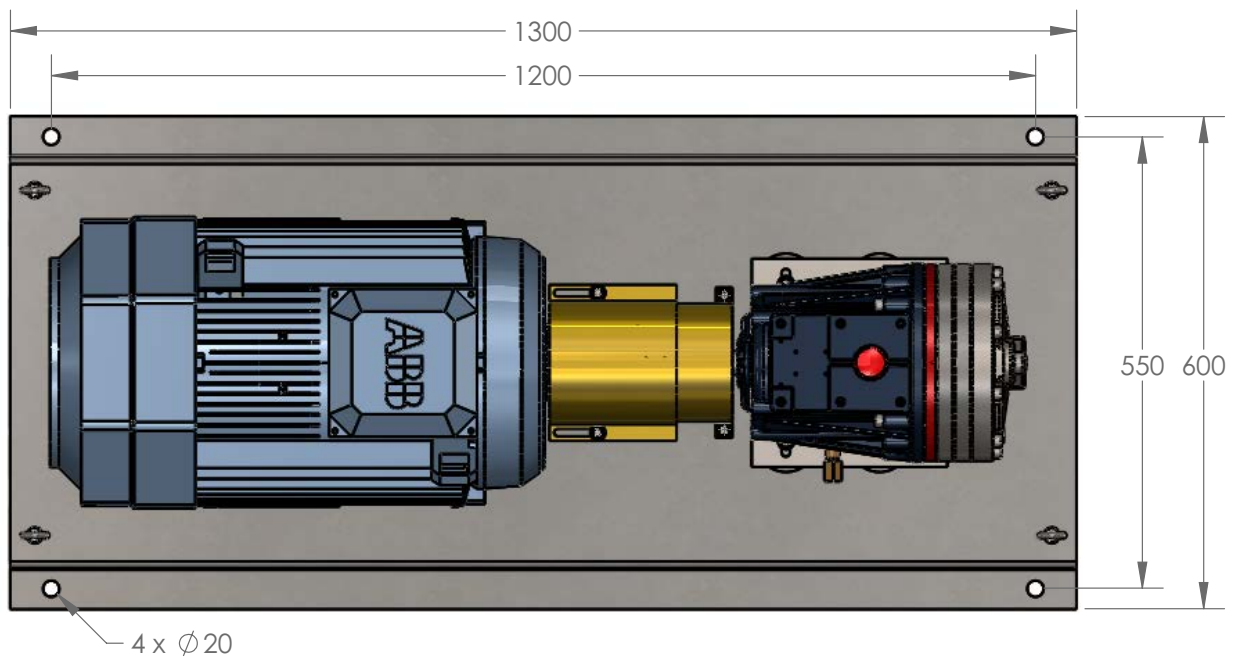

G25 Series Representative Drawings

G25 Models with Metallic Pump Head mm (Inches)

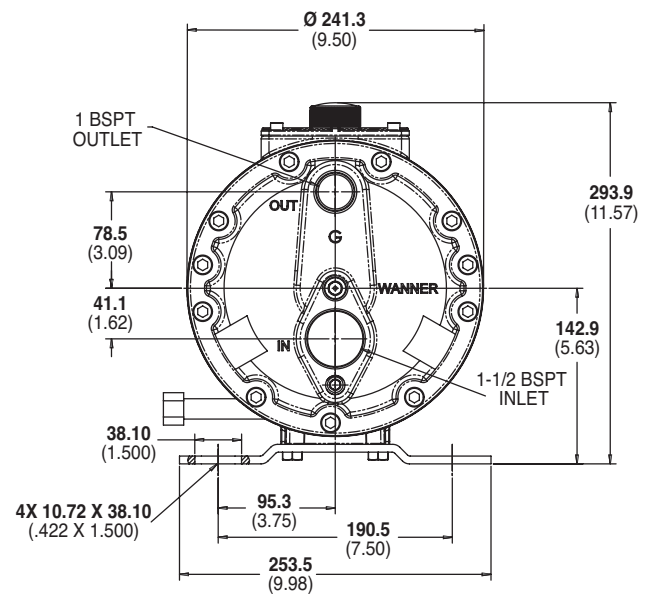
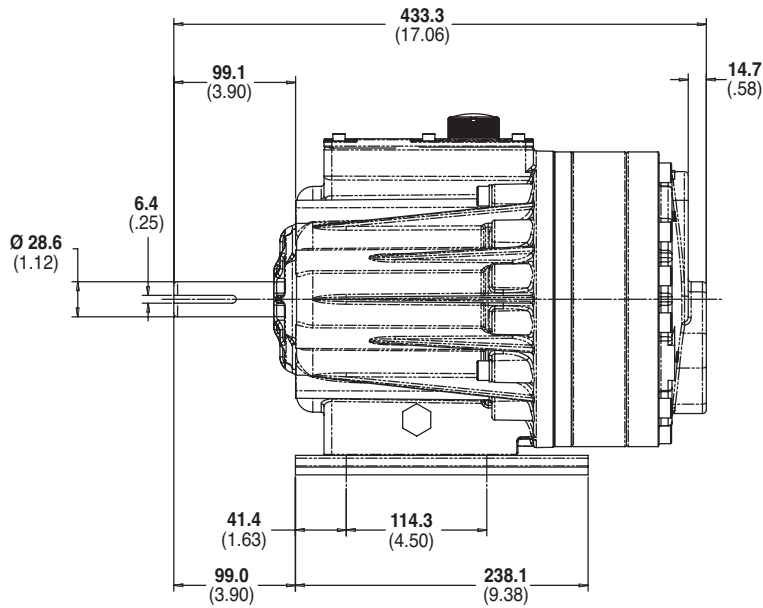

G25 Models with Non-metallic Pump Head mm (Inches)

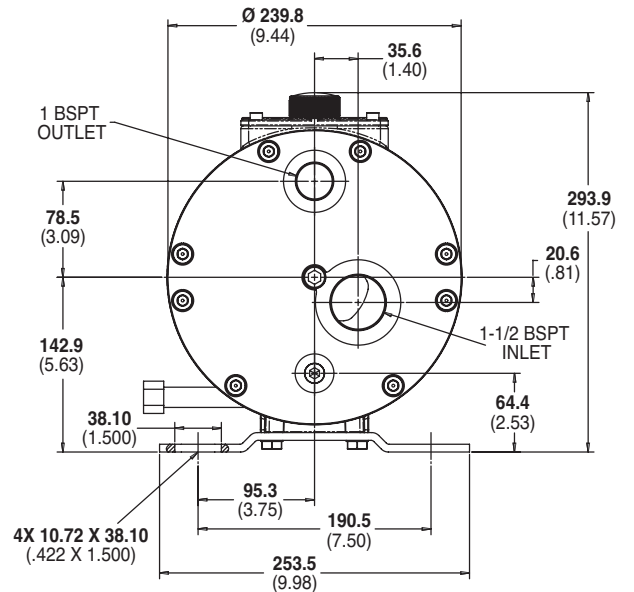
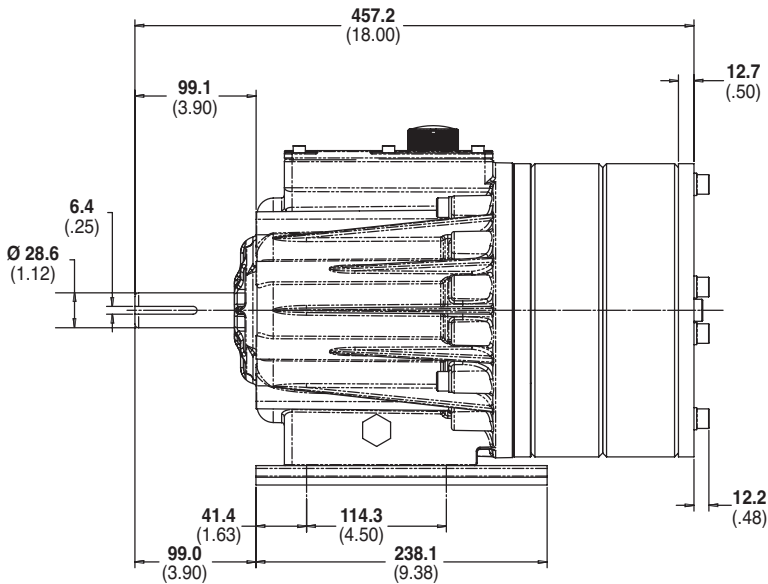

Note: Contact factory for additional drawings of specific models and configurations.

G25 Series Representative Drawings

G25 Models with Tri-clamp Flanges mm (Inches)

Maximum Discharge Pressure: 80 bar

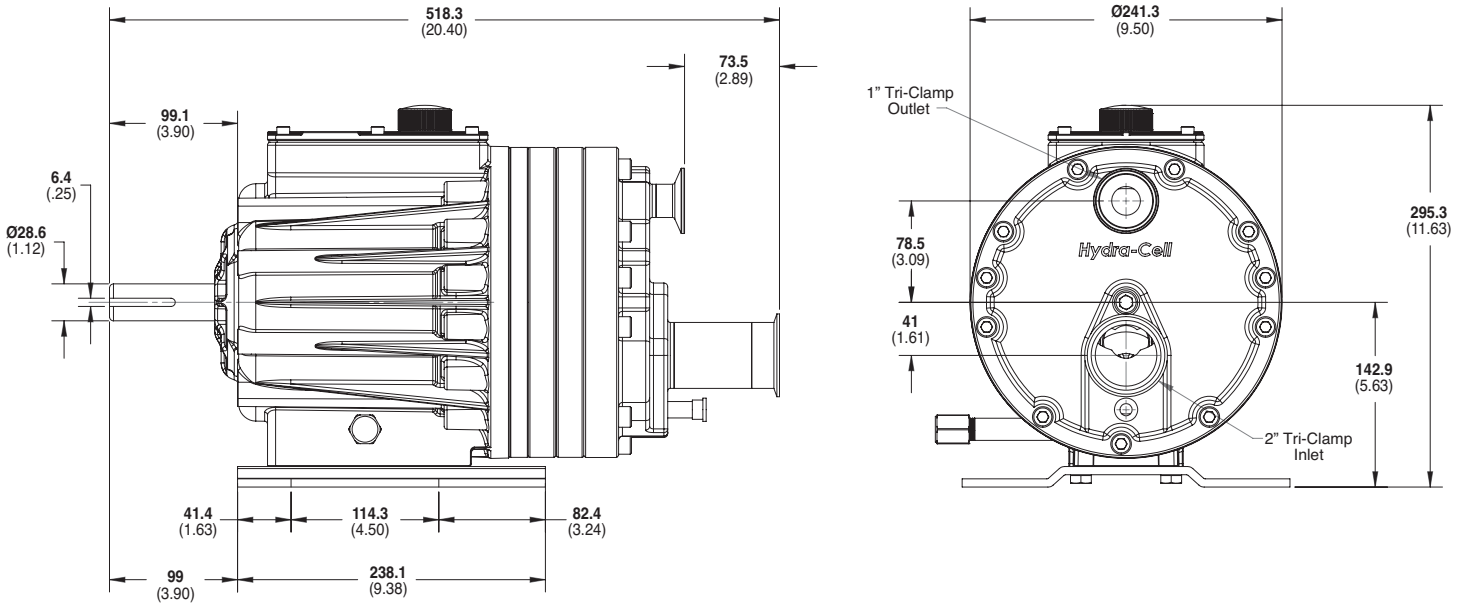

G25 Models with ANSI RF Flanges mm (Inches)

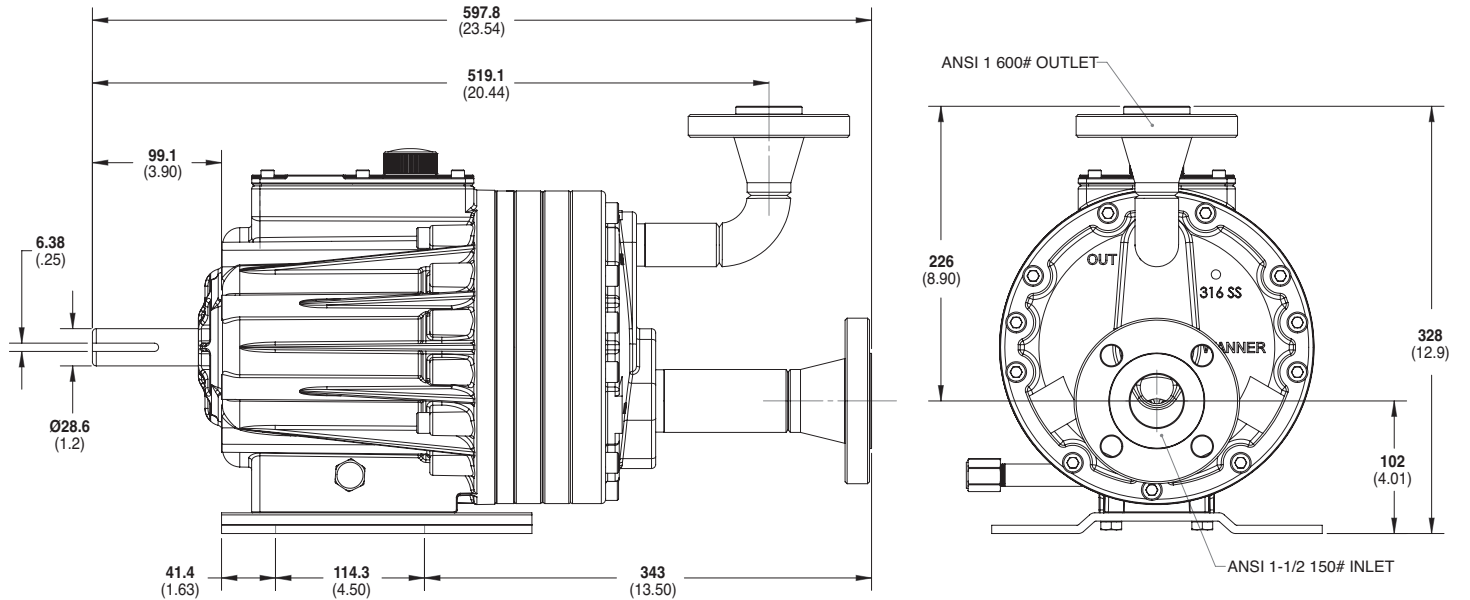

Note: Contact factory for additional drawings of specific models and configurations.

G25 Series Motor Adaptors

Pump/Motor Adaptor mm (Inches)

Part Number: A04-041-I201

Must be ordered separately for G25 models for use with IEC I32 frame motors, B35 flange.

NEMA adaptor available - consult factory.

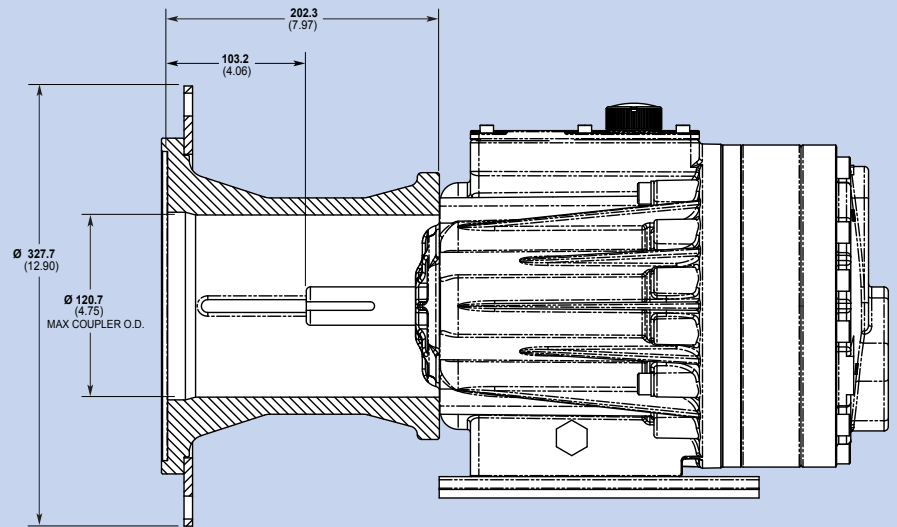

Part Number: A04-041-I203

Must be ordered separately for G25 models for use with IEC I60 frame motors, B14 flange.

NEMA adaptor available - consult factory.

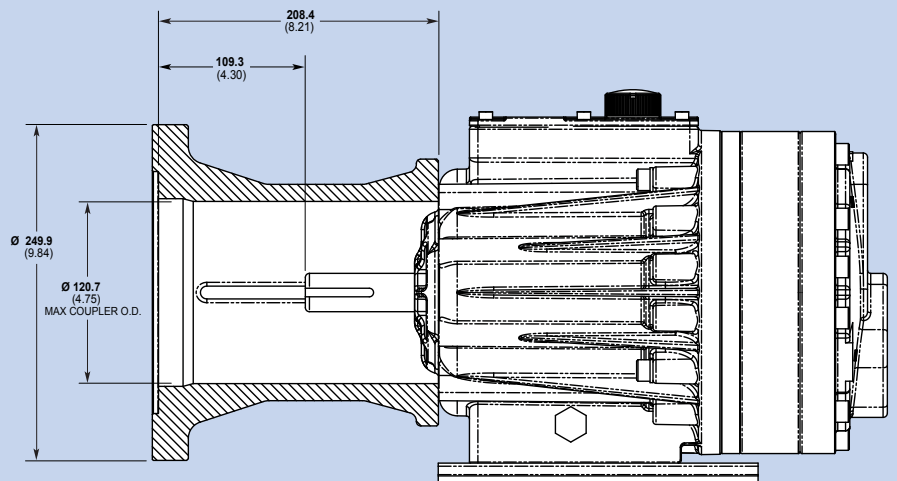

Part Number: A04-041-I205

Must be ordered separately for G25 models for use with IEC I60 - 180 frame motors, B35 flange.

NEMA adaptor available - consult factory.

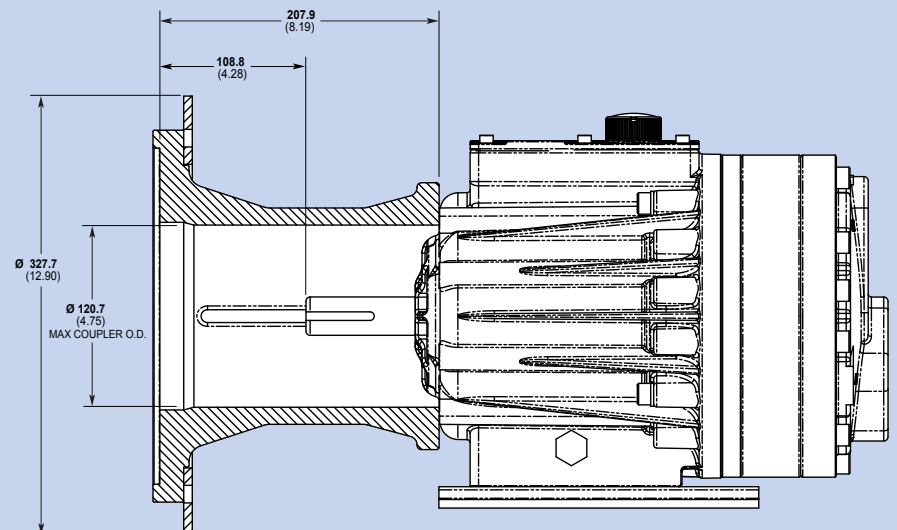

G25 Series Valves

Valve Selection

A seal-less C63 Pressure Regulating Valve is recommended for Hydra-Cell G25 pumping systems, especially for high-pressure requirements or when handling dirty fluids.



A C23 Pressure Regulating Valve provides a capable, lower-cost alternative to C63 valves for Hydra-Cell G25 pumping systems.



G25 Series How to Order

Ordering Information



A complete G25 Series Model Number contains 12 digits including 9 customer-specified design and materials options, for example: G25XXKCGNNECA.

Digit	Order Code	Description
1-3	G25	Pump Configuration Shaft-driven (BSPT Ports or ANSI Flanges)* *Pump/motor adaptors ordered separately. See previous page.
4	X	Hydraulic End Cam Max 69.0 l/min (18.2 gpm) @ 960 rpm
	E	Max 63.0 l/min (16.6 gpm) @ 960 rpm
	S	Max 50.0 l/min (13.2 gpm) @ 960 rpm
	I	Max 36.0 l/min (9.5 gpm) @ 960 rpm
5	K	Pump Head Version Kel-Cell BSPT Ports
	M	Machined housing to accept C-face pump motor adaptor/gearbox
	-	ATEX 2014/34/EU Certified, Category 2, Zone 1, Hazardous Liquids
	-	ATEX 2014/34/EU Certified, Category 3, Zone 2
		<i>Note: All options include Certificate, Oil Level Monitor or Sight Glass, Earth Stud & Secondary ATEX Label.</i>
6	B	Pump Head Material Brass
	C	Cast Iron (Nickel-plated)
	G	Duplex Alloy 2205 Stainless Steel
	M	PVDF (with Hastelloy C followers & follower screws)
	N	Polypropylene (with Hastelloy C followers & follower screws)
	P	Polypropylene (with 316L Stainless Steel followers & follower screws)
	R	316L Stainless Steel with ANSI RF Flanges, Class 150lb x 600lb
	S	316L Stainless Steel
	-	316L Stainless Steel with Tri-clamp (2" Inlet & 1" Discharge) Flanges polished to 0.8 Ra♦
	-	316L Stainless Steel with Tri-clamp (2" Inlet & 1" Discharge) Flanges polished to 0.4 Ra♦
		<i>Tri-clamp options include polishing of Pump Head, Valve Plate, Valves, Valve Seats, Springs & Retainers to 0.8 Ra or 0.4 Ra per above, Sanitary Drain along with TSE, Passivation, Surface Finish & Weld Procedure Certificates</i>
	T	Hastelloy CW12MW ♦Selecting this option will result in a Wanner International generated Pump Code, stamped onto the pump.

Digit	Order Code	Description
7	A	Diaphragm & O-ring Material Aflas diaphragm / PTFE o-ring
	E	EPDM (requires EPDM-compatible oil - Digit 12 oil code C)
	G	FKM
	J	PTFE (available with E and S cams only; 960 rpm max.)
	K	FFKM diaphragm / PTFE o-ring
	P	Neoprene
	T	Buna-N
8	C	Valve Seat Material Ceramic
	D	Tungsten Carbide (900 rpm max.)
	H	17-4 Stainless Steel
	N	Nitronic 50
	T	Hastelloy C
9	C	Valve Material Ceramic
	D	Tungsten Carbide (900 rpm max.)
	F	17-4 Stainless Steel
	N	Nitronic 50
	T	Hastelloy C
10	E	Valve Springs Elgiloy
	H	17-7 Stainless Steel
	T	Hastelloy C
11	C	Valve Spring Retainers Celcon
	H	17-7 Stainless Steel
	M	PVDF
	P	Polypropylene
	T	Hastelloy C
	Y	Nylon (Zytel)
12	A	Hydra-Oil 10W30 standard-duty oil
	B	40-wt for continuous-duty oil (use with 316L SST or Hastelloy CW12MW pump head - standard)
	C	EPDM-compatible oil
	E	Food-contact oil
	G	5W30 cold-temp severe-duty synthetic oil
	H	15W50 high-temp severe-duty synthetic oil

G25 Pump Housing is standard as Cast Aluminum. Upgrade to Ductile Iron available.

G25 Series

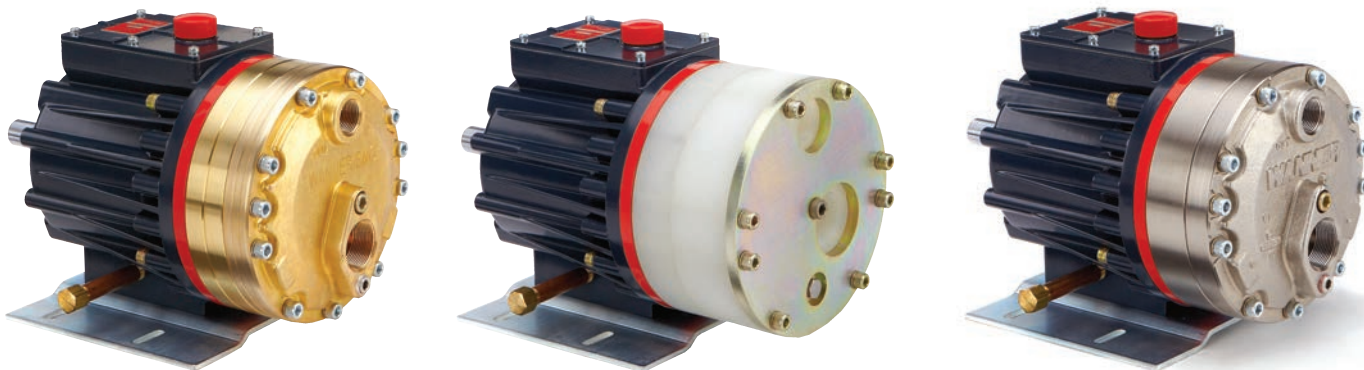

WANNER

Hydra-Cell[®]

Partners in over 70 Countries

 **Wanner International Ltd.**

**WANNER INTERNATIONAL
UNITED KINGDOM**

8 & 9 Fleet Business Park
Sandy Lane • Church Crookham
Hampshire UK GU52 8BF
t +44(0) 252 816847
e: sales@wannerint.com

 **Wanner Engineering, Inc.**

**WANNER ENGINEERING
WORLD HEADQUARTERS &
MANUFACTURING
Minneapolis USA**

t+1 612-332-5681
e: sales@wannereng.com

**REGIONAL OFFICE
Texas USA**

t+1 940-322-7111
e: sales@wannereng.com

**LATIN AMERICAN OFFICE
São Paulo, Brazil**

t +55 (11) 99582-1969
e: sales@wannereng.com

 **Wanner Pumps Ltd.**

**WANNER PUMPS
Kowloon HONG KONG**

t +852 3428 6634
e: sales@wannerpumps.com

Shanghai CHINA

t +86-21-6876 3700
e: sales@wannerpumps.com

www.hydra-cell.co.uk